

Instruction Manual

PMD-RD-000-0000-PH-0 Pyrometer

A. Specifications

- ◆ Power supply: DC12V (isolated)
- ◆ Power consumption: <2W
- ◆ Sampling rate: 4 samples/sec
- ◆ Accuracy: 0.2% full scale ±1
- ◆ Display range: -1999~9999
- ◆ Relay contact rating: 3A @ 220VAC
- ◆ Retransmit open-circuit voltage: 15V
- ◆ Outside dimensions: 48×24×75mm
- ◆ Mounting cutout dimension: 45×22mm
- ◆ LED display: 0.28" red color
- ◆ Working condition: 0~50°C, ≤85%RH



B. Front Panel

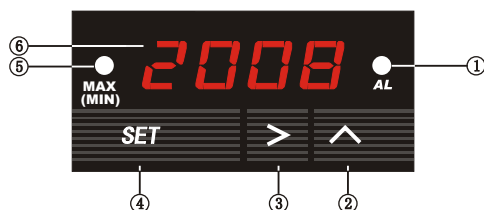

- ① Alarm and relay J1 indicator
- ② Up key
- ③ Shift key
- ④ Set key
- ⑤ Maximum and Minimum value indicator
- ⑥ Display window

1. AL on indicates alarm is on and J1 relay is pulled in (closed).
2. MAX(MIN) on when Display window shows the maximum value or the time of the Max. MAX(MIN) blinking when Display window shows the minimum value or the time of Min.
3. ">" shift key: In the parameter setting mode, press this key to select the digit to be changed. In the normal operation mode, press this key to change the display in the sequence as shown in the diagram below.

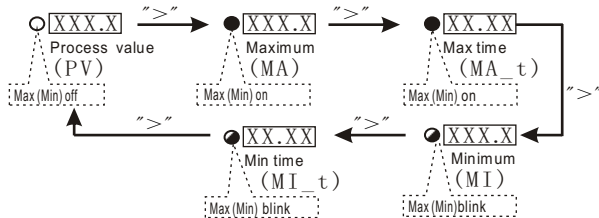

4. "A" up key . In the parameter setting mode, press it to increase the displayed value. When displaying Max/Min, press and hold it for 3 seconds to clear the Max/Min stored. In normal function, this key has two functions, show operation time and change display brightness. Press and hold it down to show the operation time since on. Release the key to show the current temperature (process value). Each time the key is pressed, the display brightness will also be changed from bright to dim or from dim to bright.

C. Parameter Setting

1, Basic Parameter (Press **SET** then input code 0089 to enter)

a) Basic Parameters description

Symbol	Description	Setting range	Initial	Note
<i>Inty</i>	Inty Input Type	See Table 1	<i>P</i>	
<i>PuL</i>	PuL Input low limit	-1999~9999	0	4
<i>PuH</i>	PuH Input high limit	-1999~9999	1000	4
<i>dot</i>	dot Decimal point	0.000~0.000	0.000	4
<i>PSb</i>	PSb Zero offset	-1000~1000	0	1
<i>PSbF</i>	PSbF Range coefficient	0.500~2.000	1.000	2
<i>CorF</i>	CorF Temperature unit	C : °C F : °F	F	
<i>FILt</i>	FILt Digital filter	0~3	0	3
<i>End</i>	End Exit			

- Note 1, for correcting the offset at zero: Display=measurement +PSb
- Note 2, for correcting the error at Max: Display=measurement x PSbF
- Note 3, Digital filter. 0=no filter. 1 weak, 2, medium, 3 strong.
- Note 4, These parameters do not apply to temperature sensors.

【Table 1】 Input type options

Symbol	Input type	Range	Res.	Accy.	Impedance
<i>t</i>	TC, Type T	-200~400°C	1°C(F)	0.3%	100K
<i>r</i>	TC, Type R	-50~1600°C	1°C(F)	0.3%	100K
<i>J</i>	TC, Type J	-200~1200°C	1°C(F)	0.2%	100K
<i>WrE</i>	TC, WRe3-WRe25	0~2300°C	1°C(F)	0.2%	100K
<i>b</i>	TC, Type B	350~1800°C	1°C(F)	0.3%	100K
<i>S</i>	TC, Type S	-50~1600°C	1°C(F)	0.3%	100K
<i>P</i>	TC, Type K	-200~1300°C	1°C(F)	0.2%	100K
<i>E</i>	TC, Type E	-200~900°C	1°C(F)	0.2%	100K
<i>P100</i>	RTD, Pt100	-199.9~600.0°C	0.1°C(F)	0.2%	(0.2mA)
<i>Cu50</i>	RTD, Cu50	-50.0~150.0°C	0.1°C(F)	0.5%	(0.2mA)
<i>375r</i>	0~375 Ω Pressure			0.2%	(0.2mA)
<i>75nu</i>	0~75mV Current			0.1%	100K
<i>30nu</i>	0~30 mV			0.1%	100K
<i>5u</i>	0~5 V			0.1%	100K
<i>1-5u</i>	1~5 V			0.1%	100K
<i>10u</i>	1~10 V			0.1%	100K
<i>10nA</i>	0~10 mA			0.3%	150Ω
<i>20nA</i>	0~20 mA			0.2%	150Ω
<i>4-20</i>	4~20 mA			0.2%	150Ω

(TC, thermocouple sensor)

B) Basic Parameter setting (See 【Fig3】)

2, Alarm Parameter (Press **SET** then input code 0001 to enter)

a) Alarm Parameters description

Symbol	Name	Description	Range	Initial	Note
<i>AH1</i>	AH1	J1 pull in Value	-1999~9999	900	4
<i>AL1</i>	AL1	J1 drop out value	-199~9999	800	
<i>AH2</i>	AH2	J2 pull in Value	-1999~9999	900	
<i>AL2</i>	AH2	J2 drop out Value	-1999~9999	800	
<i>End</i>	End	Exit			

b) Alarm Parameter setting is similar to the Basic Parameters setting in Fig. 3 except access code is 0001 instead of 0089.

Note 4. Relay action setting (SYL-1812 does not contain J2 relay. Its setting (AH2, AL2) can be ignored).

- 1) Set AH1=AL1, relay is disabled.
- 2) Set AH1>AL1, relay is for high limit alarm. See Fig. 1
- 3) Set AH1<AL1, relay is for low limit alarm. See Fig. 2.

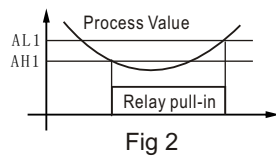
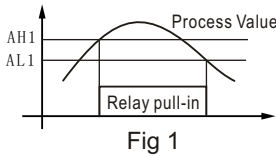

【Fig 3】 Basic Parameter setting flow chart:

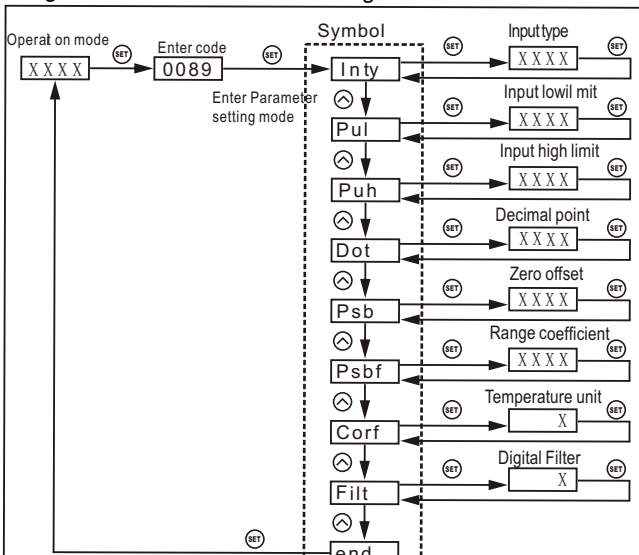

- Quick guide,
- 1) Press **SET** to enter setting mode.
 - 2) Use **⊙** and **⊚** to input code or parameter. 3) Use **SET** to confirm.
 - 4) Use **⊙** to select the next parameter.
 - 5) When no key is pressed for ~ 50 sec, the meter will return to normal mode.

3. Peak Value (Press **SET**, then input code 0037 to enter)

a) Peak value description

Symbol	Name	Description	Range	Initial	Note
$\bar{n} \bar{R}$	MA	Maximum value	$\bar{0} \bar{n} / \bar{0} \bar{F} \bar{F}$	$\bar{0} \bar{n}$	5
$\bar{n} \bar{R} - t$	MA-t	Time of maximum	$\bar{0} \bar{n} / \bar{0} \bar{F} \bar{F}$	$\bar{0} \bar{F} \bar{F}$	
$\bar{n} \bar{l}$	MI	Minimum value	$\bar{0} \bar{n} / \bar{0} \bar{F} \bar{F}$	$\bar{0} \bar{F} \bar{F}$	
$\bar{n} \bar{l} - t$	MI-t	Time of minimum	$\bar{0} \bar{n} / \bar{0} \bar{F} \bar{F}$	$\bar{0} \bar{F} \bar{F}$	
$\bar{E} \bar{n} \bar{d}$	End	End			

Note 5, Peak function is inter locked.

- 1) When MA is turned off, MA-t can't be set.
- 2) When MI is turned off, MI-t can't be set.

b) Peak Value setting is similar to the Basic Parameters setting in Fig. 3 except access code is 0037 instead of 0089.

c) Reset the peak value

The peak values is stored in the memory even the meter is powered off. To reset them, change display to show MA, MA-t, MI or MI-t. Then, press and hold "Λ" key for 3 seconds. The display will show "----", indicating the memory (for all four parameters) is reset. The meter will start to catch the new peak after 2 seconds.

4. Retransmit (Press **SET**, then input code 0036 to enter)

a) Retransmit parameters description

Symbol	Name	Description	Range	Initial	Note
$\bar{0} \bar{b} \bar{t} \bar{y}$	obty	Output type	0-20/4-20 mA	4-20	6
$\bar{0} \bar{b} \bar{L}$	obL	output low limit	-1999-9999	000.0	7
$\bar{0} \bar{b} \bar{H}$	obH	output High limit	-1999-9999	100.0	8
$\bar{E} \bar{n} \bar{d}$	End	Exit			

b) Retransmit (analog output) parameter setting is similar to the Basic Parameters setting in Fig. 3 except access code is 0036 instead of 0089.

Note. 6, Output type selection. User can select either 0-20 mA or 4-20 mA.

Note 7. Output lower limit. The LED display value when output is at 0 mA or 4 mA. e.g. If you want 100 C to output 0 mA, set obL=100

Note 8. Output high limit. The LED display value when output is at 20 mA. e.g. If you want 1000C to output 20 mA, set obH= 1000. This number will affect the resolution of the signal.

D. Terminal assignment

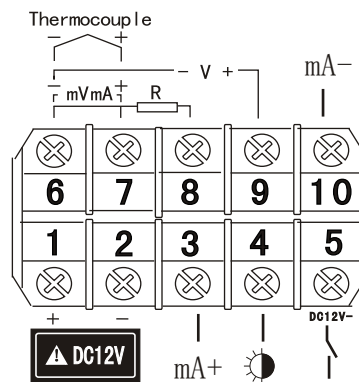

- 1) 1 and 2 are for power input
- 2) 2 and 5 are for alarm relay output. When alarm isturned on, 2 and 5 is connected. To drive a 12 V buzzard, connect one lead of the buzzard to the +12V. Connect the other lead to terminal 5.
- 3) 4 is for display brightness control. When connecting the illumination signal (+12 V) to it, the brightness with synchronized with headlight. If not connected, the brightness can still be controlled by "Λ" up key.
- 4) 6, 7, 8 and 9 are for different types of signal input. Use 6 and 7 for thermocouple input. Use 6,7 and 8 for RTD sensor input. Use 6 and 9 for pressure sensor.
- 5) 3 and 10 is for retransmit (analog output). To change the output from current to a voltage, install a 1% precision resistor between terminal 3 and 10. With a 250Ω Resistor, 1~5V, 0~5V output can be obtained. With 500Ω resistor, 2-10V or 0~10V output can be obtained.

E. Application examples

1) Exhaust Gas Temperature (EGT) measurement

The meter is preset for the EGT application. Wire the meter as the diagram below. It is ready to run.

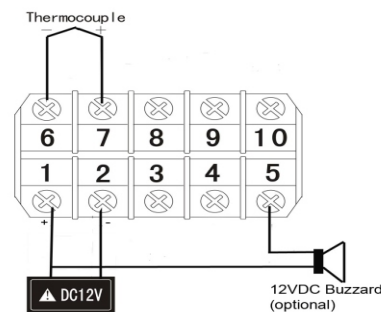

The Sensor Connection

675 East Big Beaver Road, Suite 111, Troy, MI 48083 USA

Tel 248-417-2622

sales@thesensorconnection.com